



ISSN: 2350-0328

**International Journal of Advanced Research in Science,
Engineering and Technology**

Vol. 10, Issue 5, May 2023

Analysis of the Joint Operation of the Detandar-Generator Unit and Air Heat Pump

Mukolyants Arsen Artyomovich, Ergasheva Dilbar Kuchkarovna

Tashkent State Technical University named after Islam Karimov, Uzbekistan, Tashkent

ABSTRACT: Calculations of the energy efficiency of the expander-generator unit under various operating conditions during heating of natural gas in front of the expander using a heat pump unit were carried out. It is shown that the introduction of expander-generator units in the gas supply system of the Republic of Uzbekistan, with a properly selected gas heating system, can be thermodynamically and technically and economically advantageous. The results of the thermodynamic analysis of the developed energy-technological complex in the production of electricity are presented.

KEYWORDS: transported natural gas, main gas pipeline, pressure drop, heat pump unit, heating of transported gas, expander-generator, energy efficiency, power generation, energy saving.

I. RELATED WORK

Due to the fact that the temperature of the gas leaving the expander can be considerably lower than the permissible operating conditions after expansion in the expander, the gas in the expander-generator unit (EDU) is heated. Typically, this heating is done before the expander and in most cases utilizes high potential energy obtained from fuel combustion. Although the thermal efficiency of EDU in this scenario is much higher than that of conventional power generation plants (e.g. thermal power plants), it still requires fuel consumption to operate.

There is a method of operating expander installations that allows the use of low-potential energy from secondary energy sources or the environment for gas heating before the expander [1-2]. With this method of expander operation, there is no need for fuel combustion. Gas heating before the expander is carried out using a heat pump unit (HPU) that increases the temperature of low-potential sources to the required level. EDU generates part of the electricity required for HPU operation.

II. INTRODUCTION

Fuel-free operation of EDU is also possible in installations that include an expander-generator unit, an air compressor, and an air turbine as their main components [3-5]. The principal scheme of the installation, which can produce both electricity and cooling, is shown in Fig.1.

The installation operates as follows. High-pressure gas 1 is heated in heat exchanger 2 with heat supplied by air and is then piped 3 to the expansion in expander 4 before being piped 5 to the low-pressure gas pipeline. Atmospheric air 6 is compressed in air compressor 7 and directed 8 to heat exchanger 2, where it loses heat to the gas from compression in compressor 7 before being expanded in the air turbine 9. The expanded air is cooled in heat exchanger 10 before being piped 12 to atmosphere (a variant is possible in which air is expelled after the air turbine directly to the atmosphere, bypassing heat exchanger 10). A pump 13 is provided for circulating the coolant. The air compressor 7 is coupled with the air turbine 9 and electric motor 14 forming a single rotor assembly. Some of the electrical power generated by power generator 15 drives electric motor 14, with the remaining electricity being supplied to the grid.

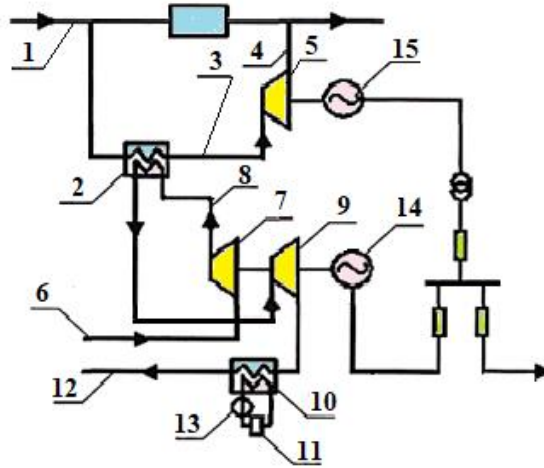

Figure 1. Schematic diagram of a fuel-free energy installation

Processes occurring in the air compressor and turbine (Fig. 2a) and expander (Fig. 2b) are represented in h-s diagrams in Fig. 2. (For diagram simplification, gas and air pressure losses in the heat exchanger and piping are not taken into account).

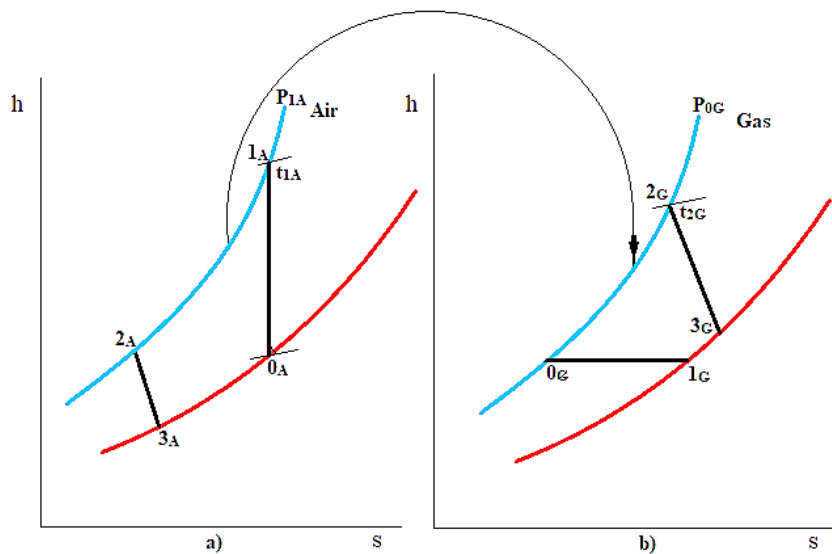

Figure 2. Processes in the h-s diagram

Air enters the compressor at ambient conditions (point 0_A in Fig. 2a) with temperature T_{0A} and pressure p_{0A} . The air is compressed to the required pressure p_{1A} (point 1_A), and then enters the heat exchanger where it is heated before passing through the expander. The necessary pressure for the air after the compressor is determined by the temperature T_{1A} , which is required for heat exchange with the heated gas at the outlet of the heat exchanger (for convenience, it is assumed that the heat exchanger is countercurrent). This ultimately determines the necessary gas temperature T_{2G} before the expander (Fig. 2b). After releasing heat to the gas in the heat exchanger, the air with parameters p_{2A} and T_{2A} (point 2_A in Fig. 2a) enters the air turbine. The temperature T_{2A} must be such that heat exchange can be achieved between the air and the heated gas, meaning that the air temperature T_{2A} must be greater than the gas temperature T_{0G} . The expanded air from the turbine, which performs mechanical work, enters the refrigeration heat exchanger with parameters at point 3_V , or is discharged into the atmosphere. The mechanical work produced by the air turbine is used to drive the air compressor.

The transported gas enters the installation from the high-pressure pipeline with parameters of p_{0G} and T_{0G} (point 0_G in Fig. 2b). When a throttling device is used for technological pressure reduction of gas, the gas parameters after

throttling are determined by point 1_G (assuming that the throttling process is adiabatic, which is sufficiently close to realistic conditions). The gas in the heat exchanger is heated to parameters determined by point 2_G on Fig. 2b by using heat transferred by the air. After the heat exchange, the gas with parameters p_{2G} and T_{2G} enters the expander. After expansion, the gas enters the low-pressure pipeline (point 3_G in Fig. 2b). The pressure p_{3G} is determined by the required operating conditions of the pressure reduction station. The enthalpy h_{3G} of the gas and its temperature T_{3G} after the expander depend on the temperature to which the gas was heated before the expander and the internal relative efficiency of the expander. Obviously, the gas after expansion in the expander may have an enthalpy either equal to, greater than, or less than its enthalpy before the heat exchanger (as shown in Fig. 2b). The mechanical work produced by the expander, proportional to the difference in enthalpies of the gas at points 2_G and 3_G, is converted into electrical power in the generator. One part of that power must be used to drive the air compressor, while the other part, representing the useful power generated by the installation, can be transferred to the electricity consumer.

Thus, the installation comprising the expander-generator unit, air compressor, and air turbine can generate useful electrical power and cold without burning fuel.

To explain which energy is converted into electrical power in the installation, let us consider the energy flows at its inlet and outlet (Fig. 3).

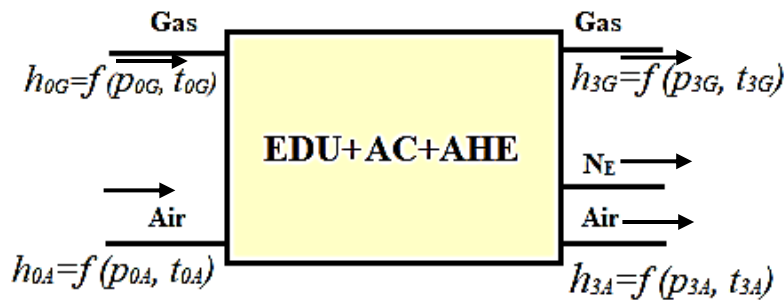

Figure 3 Energy Flow Diagram

The setup includes air with pressure p_{0A} and temperature T_{0A}, and gas with pressure P_{0G} and temperature T_{0G}. At the outlet of the setup, the air has a pressure of P_{3A} and a temperature of T_{3A}, and the gas has a pressure of P_{3G} and a temperature of T_{3G}. In addition, the setup produces electrical power N_E. The air flow rate at the inlet and outlet of the setup is G_A, and the gas flow rate is G_G. The energy balance equation for the setup can be written as:

$$G_A h_{0A} + G_G h_{0G} = G_A h_{3A} + G_G h_{3G} + N_E \tag{1}$$

or

$$G_A (h_{0A} - h_{3A}) = G_G (h_{3G} - h_{0G}) + N_E \tag{2}$$

From equation (2), it can be seen that energy from the low potential energy of the surrounding environment, proportional to the enthalpy difference of the air at the inlet and outlet of the setup, is used to produce electrical power N_E and increase the enthalpy of the gas at the outlet compared to the inlet.

From the analysis, it can be concluded that to achieve maximum efficiency of the setup, the air temperature T_{3A} at the turbine outlet should be as low as possible. This can be achieved by reducing the temperature difference between the air at the outlet of the heat exchanger and the heated gas, as well as using air turbines with high internal relative efficiencies.

To obtain analytical dependencies for calculating the useful power of the setup at various process parameters, and to investigate the effect of these parameters on efficiency, a mathematical model of the setup was developed. It includes a gas turbine engine, air compressor and turbine, and the following dependencies, conditions, and constraints are included:

An equation to determine the useful electrical power of the setup, i.e. the power that can be delivered to the consumer:

$$N_{UEP} = N_{EDU} + N_{AT} - N_C \tag{3}$$

Equations to determine the electrical power generated by the gas turbine engine:

$$N_{EDU} = G_G \cdot (h_{2G} - h_{3G}) \tag{4a}$$

or:

$$N_{EDU} = G_G c_{pG} \cdot (T_{2G} - T_{3G}) \quad (4b)$$

or:

$$N_{EDU} = G_G T_{2G} \frac{k_G}{k_G - 1} R_G \left(1 - \left(\frac{p_{3G}}{p_{0G}} \right)^{\frac{k_G - 1}{k_G}} \right) \eta_E \quad (4c)$$

Equations to determine the electrical power generated by the air turbine:

$$N_{AT} = G_A (h_{2A} - h_{3A}) \quad (5a)$$

or:

$$N_{AT} = G_A c_{pA} \cdot (T_{2A} - T_{3A}) \quad (5b)$$

or:

$$N_{AT} = G_A \frac{k_A}{k_A - 1} R_A T_{2A} \left(1 - \left(\frac{p_{3A}}{p_{2A}} \right)^{\frac{k_A - 1}{k_A}} \right) \eta_{AT} \quad (5c)$$

Equations to determine the electrical power consumed by the compressor drive:

$$N_C = G_A (h_{2A} - h_{0A}) \quad (6a)$$

or:

$$N_C = G_A c_{pA} \cdot (T_{1A} - T_{0A}) \quad (6b)$$

or:

$$N_{AC} = G_A \frac{k_A}{k_A - 1} R T_{0A} \left[\left(\frac{p_{1A}}{p_{0A}} \right)^{\frac{k_A - 1}{k_A}} - 1 \right] \frac{1}{\eta_C} \quad (6c)$$

Equations for the heat balance of the gas-air heat exchanger:

$$G_G \cdot (h_{2G} - h_{0G}) = G_A (h_{1A} - h_A) \eta_{HE} \quad (7a)$$

or:

$$G_G c_{p,G} \cdot (T_{2G} - T_{0G}) = G_A c_{p,A} \cdot (T_{1A} - T_{2A}) \eta_{HE} \quad (7b)$$

Dependencies establishing the relationship between the air and gas temperatures at the inlet and outlet of the gas-air heat exchanger (assuming that the heat exchanger is countercurrent):

$$T_{1A} = T_{1G} + \mathcal{Q}_1 \quad (8)$$

$$T_{2A} = T_{0G} + \mathcal{Q}_2 \quad (9)$$

Dependencies taking into account the pressure drop of air and gas in the gas-air heat exchanger:

$$p_{2A} = p_{1A} - \Delta p_A \quad (10)$$

$$p_{2G} = p_{0G} - \Delta p_G \quad (11)$$

Change in the enthalpy of the gas stream (physical heat of fuel) upon further combustion:

$$\Delta q_{ph,h} = G_G \cdot (h_{3G} - h_{1G}) \quad (12)$$

III.CONCLUSION

The air pressure at the inlet of the compressor and at the outlet of the air turbine (or at the outlet of the heat exchanger of the refrigeration unit if present) is equal to atmospheric pressure. It should be noted that equations (4c), (5c), and (6c) can only be applied when the pressures of the flows are small and the properties of the gas and air are insignificant from the properties of ideal gas.

Calculations were carried out to estimate the useful power of the unit using the following initial data:



1. The gas pressure at the inlet to the expander and at the outlet from it $p_{0G} = 5$ MPa and $p_{3G} = 1.5$ MPa, respectively.
2. The electric power of the expander-generator unit is 5 MW.
3. The gas temperature at the inlet of the gas-air heat exchanger is 0°C .
4. The efficiency of the gas-air heat exchanger is 0.97.
5. The efficiency of the compressor is $\eta_C = 0.7$.
6. The efficiency of the air turbine is $\eta_{AT} = 0.85$.
7. The differences between the air and gas temperatures at the inlet and outlet of the gas-air heat exchanger are 5°C .

8. No pressure drop of gas and air in the gas-air heat exchanger was taken into account.
Data from were used to determine the enthalpies of the gas and air.

Under the adopted conditions, the useful power of the unit was 2.05 MW, the power of the air turbine was 3.26 MW, and the power consumed by the compressor was 6.21 MW. The air temperature at the inlet of the gas-air heat exchanger was 60.3°C , and the air temperature at the outlet of the air turbine was -27°C .

Thus, under the accepted conditions, the useful power of the installation turned out to be equal to about 40% of the power generated by the expander generator unit.

1. The unit combining a deaerator generator set, air compressor, and turbine allows obtaining electric energy without fuel expenses.
2. The useful electric power, i.e., the power that can be delivered to the consumer, under the adopted conditions, is about 40% of the power generated by the EDU.

REFERENCES

- [1] V.S. Agababov, Yu.M. Arkharov, A.Yu. Arkharova Detander-generating plant / Patent for utility model No. 49199 of the Russian Federation, IPC 7 F 25 B 11/02, F 01K 27/00 dated 24.05.2005. Published on 10.11.2005. Bulletin No. 31.
- [2] A A Mukolyants, M D Buranov, I V Sotnikova and H F Makhmudov. Operation analysis of expander-generator unit at a gas distribution station. Journal of Physics: Conference Series. 2020. Journal of Physics: Conference Series 1515 022053 <https://doi:10.1088/1742-6596/1515/2/022053>.
- [3] M. Buranov, A. Mukolyants and I. Sotnikova 2019 J. Phys.: Conf. Ser. 1399 055038 doi:10.1088/1742-6596/1399/5/055089.
- [4] A.A. Mukolyants, I.V. Sotnikova, D.K. Ergasheva, N.E Karimova Study of efficiency of schemes of fuel-free units of electric power generation in a gas supply system. International Journal of Advanced Science and Technology. Vol. 29, No. 7, (2020), pp. 9269-9273
- [5] Mukolyants A.A., Sotnikova I.V., Buranov M.D., Taubaldiyev A.A., Improving the efficiency of air transport heat pump unit in the expander-generator unit, German International Journal of Modern Science №8, 2021. DOI: 10.24412/2701-8369-2021-8-1-49-51