



ISSN: 2350-0328

**International Journal of Advanced Research in Science,
Engineering and Technology**

Vol. 8, Issue 5 , May 2021

Development of Mathematic Model of Automatic Control System for Irrigation Water Treatment with a Set Mineralization

Gaziyeva Rano, Ozodov Ezozbek

Department of Automation and control of technology process, Tashkent Institute of Irrigation and Agricultural Mechanization Engineers, Koriy-Niyoziy 39, 100000, Tashkent, Uzbekistan

ABSTRACT: This article discusses the development of an automatic decision-making system for a device aimed at reducing the level of mineralization by diffusion mixing. The article aimed at disclosing the issue of preserving the specified volume of salinity of the structure by automatically controlling the salt concentration and the level of irrigation water salinity. The article presents a mathematical justification, models of technological process control, technical implementation of the control concept and research results.

KEYWORDS: automation, irrigation, water treatment, programming, electronics, automatic control, mathematic model.

I. INTRODUCTION

Water scarcity considered an urgent problem not only in our country; it is a global problem on which a lot of effort and pay attention by international organizations, countries and many scientific institutions. Lack of drinking resources, taking into account the rising demographics, leads to the fact that many countries are included in the list of suffering from water stress. It is worth noting that, 2021, our republic ranked 25th out of 164 countries in the world ranking (World Resources Institute) as a country suffering from water stress. According to the researches, Uzbekistan is included in a group of 27 countries experiencing high water scarcity among countries such as Afghanistan, Turkey, Kyrgyzstan, Portugal and Italy. The hydropower resources of Uzbekistan make up 4.92% of the entire territory of the country, the total water resources are 60 km³ per year, of which only 12.2 km³ is formed on the territory of the republic, the rest of the water comes from outside from the Tien Shan and Altai mountains from the snow and glaciers of these mountains. The main part of water resources goes to irrigate cotton fields and other agricultural needs [1].

The population of the republic by 2030 is project to increase to almost 40 million people, which will cause a decrease in available water resources by 7-8 km³.

Total water secures of republic decries from the current 13-14% to 44-46%, which will slow down the development of not only agriculture, but also other industries. According to the World Bank, losses of drinking water in Uzbekistan in 2018 amounted to 469 million cubic meters, or 32% of the total volume of drinking water [2].

Considering the above facts, the provision of high-quality irrigation water for irrigation is consider a strategically important aspect of our country. In contrast to drinking needs, agriculture consumes a large amount of water with relatively low requirements. The purification process obtaining data on water quality should be as prompt as possible and the accuracy of water quality is very important. Considering that the irrigation process is carry out in the fields, the portability of the cleaning device is also important. The above requirements can be technically implemented using precise measurement and control of the actuators, these two aspects can be implementing in combination using special automatic control systems that simultaneously control the quality of the irrigation water and the operating modes of the actuators [3].

II. RESEARCH METHOD

The programming technique based on the design features of the device and taking into account the technical parameters of the measuring instruments. The creation of control and interaction commands is based on a given flowchart algorithm. [4].

A. OBJECT OF RESEARCH

The object of research is construction for the selective choice of purification or direct supply of water to the mixing capsule.

The basic principle of operation of the proposed design is to create the required concentration of water with an acceptable salt content inside the tank and then transfer it for irrigation [5].

The device consists of 5 parts; 1- conduct metric sensor that will be installed in the water source to determine the salt content in the source, 2- centrifugal pump for water transfer, 3- on-off solenoid valves for water distribution, 4- reverse osmosis to lower the salt level in the water, 5- capsules for collecting water (see Figure 1) [6].

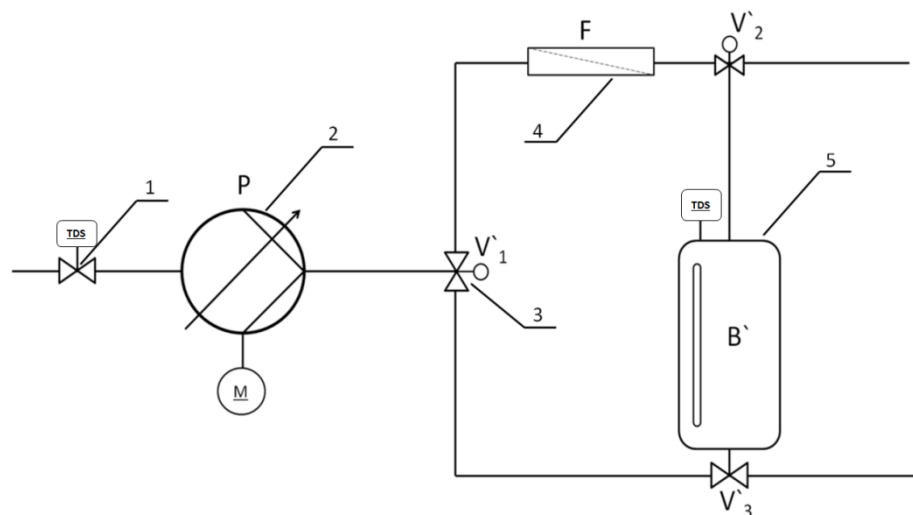

1-conductometric sensor; 2-pump unit; 3- two position valve; 4- reverse osmosis; 5- diffused capsule.

Fig. 1. Diffusion mixing design.

The principle of operation of the design is that the electromagnetic control valve V_1 distributes water for cleaning using reverse osmosis, valve V_2 is used to supply purified water to the capsule, valve V_3 is used to supply mixed water for irrigation. The valve operating time and the volume of water flow distribution for cleaning and for direct transfer to the capsule depends on the salinity of the water source. The data that transmitted from the first sensor goes to the controller and then the controller, based on the built-in algorithm, sets the operating time of the on-off valves. The level of reverse osmosis load depends on the salinity of the water source and thus it is possible to extend the level of operation of reverse osmosis by creating an individual regime depending on the degree of salinity of the water [8,9].

III. RESULTS OF RESEARCH

The object of the study is the method of batch mixing in which water of high concentration is mixing with water of low order of mineralization in the practice of irrigation (see Figure 1), it is necessary to obtain water with a certain content of minerals. It is achieved by mixing water with a low amount of minerals with some water of high mineralization [5]. This process schematically (see Figure 2).

This figure shows the scheme of water intake numbered; through Q, C with the corresponding indices indicate the flow of water and the concentration of minerals. For concreteness, we have $C_1 < C_2$. It is obvious that the concentration of minerals in the resulting mixture satisfies the condition $C_1 \leq C \leq C_2$.



Fig.2. Mixing process.

It is necessary to build a control system that provides and maintains some required values of the mineral concentration $C=C_T$ at the mixer outlet.

The required mineral concentration value also satisfies the inequality:

$$C_1 \leq C \leq C_2 \tag{1}$$

If m_{1w} , m_{2w} were the masses of pure water; μ_1 , μ_2 be the masses of minerals contained in the water.

Degree of mineralization in the first pipe:

$$k_1 = \frac{\mu_1}{m_1} = \frac{\mu_1}{m_{1w} + \mu_1} = \frac{1}{\frac{m_{1w}}{\mu_1} + 1} \tag{2}$$

In second pipe it will be:

$$k_2 = \frac{\mu_2}{m_2} = \frac{\mu_2}{m_{2w} + \mu_2} = \frac{1}{\frac{m_{2w}}{\mu_2} + 1} \tag{3}$$

For the degree of mineralization of the prepared water, we have:

$$k = \frac{k_1 m_1 + k_2 m_2}{m_1 + m_2} = \frac{m_1}{m} k_1 + \frac{m_2}{m} k_2 \tag{4}$$

There is a ratio between mass and volume:

$$m = \rho Q \tag{5}$$

In equation 5 ρ - density; Q -volumetric flow.

It's obvious that

$$Q = Q_1 + Q_2 \tag{6}$$

In taking into account the last two expressions, it is easy to obtain from expression (4):

$$k = \frac{\rho_1 Q_1}{\rho_1 Q_1 + \rho_2 Q_2} k_1 + \frac{\rho_2 Q_2}{\rho_1 Q_1 + \rho_2 Q_2} k_2 \tag{7}$$

The concentration of minerals defined as the ratio of their mass to the volume of the solution, that is:

$$c = \frac{\mu}{Q} \tag{8}$$

In result, we get the output stream we get:

$$c = \frac{c_1 Q_1 + c_2 Q_2}{Q_1 + Q_2} \tag{9}$$

$$c = \frac{k_1 \rho_1 Q_1 + k_2 \rho_2 Q_2}{Q_1 + Q_2} \tag{10}$$

Comparison of expressions (9) and (10) yields the relation and has following form (11)

$$c = xp \tag{11}$$

Possible technological schemes. The following variants of the schemes for the formation of water with the required concentration of minerals are possible:

- a) Regulating by the flow of highly mineralized water Q_2 (fig. 3 a)
- b) Regulation of low-salinity water flow Q_1 (fig. 3 b)
- c) Regulation of both streams (fig. 3 c).

Technological schemes corresponding to the listed options shown in Fig. 2. Q_{10} , Q_{20} - maximum possible water discharge, respectively, through channels 1 and 2;

Z_1 , Z_2 setting signals of automated gates for the corresponding channels. The change in technological variables in time is describing through a set of operator relations. Also, for option:

- (a) Work on principal $Q_1(t) = Q_{10}(t)$, and (b) works on $Q_2(t) = Q_{20}(t)$ equation

When using option (a) of the technological scheme, the required concentration can be set only in accordance with the following inequality:

$$c_1 \leq c_T \leq \frac{c_1 Q_{10} + c_2 Q_{20}}{Q_{10} + Q_{20}} < c_2 \tag{12}$$

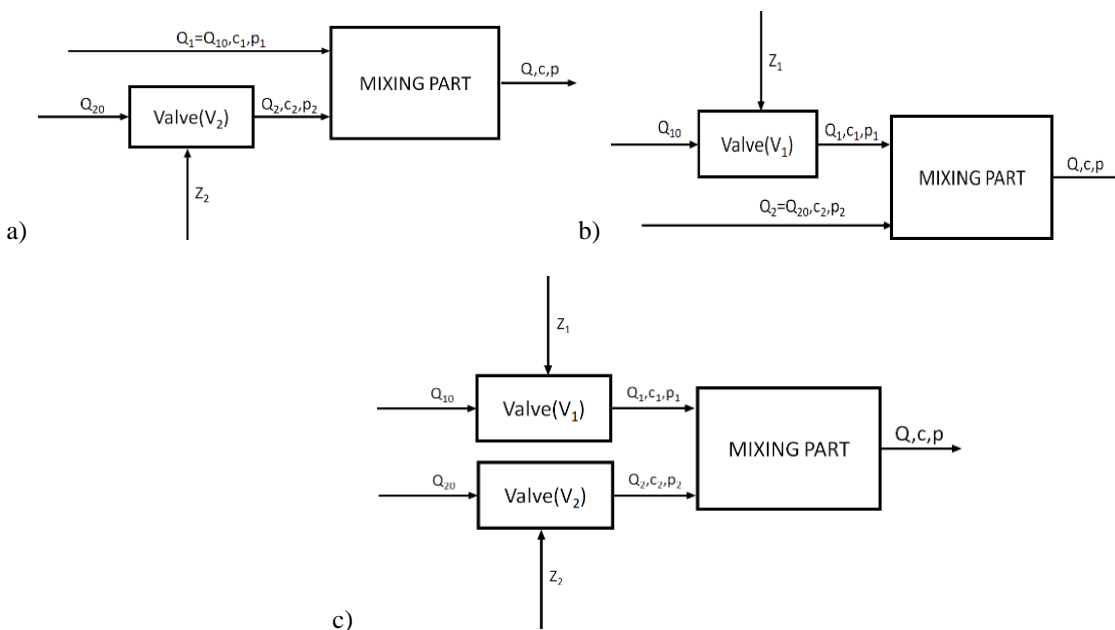

Fig. 3. Technological schemes of concentration formation minerals in water

Option (b) also does not provide the ability to control the volume of the output stream. In this case, the input stream is unmanaged. Q_2 . Input stream Q_1 satisfies the inequality:

$$0 \leq Q_1(t) \leq Q_{10}(t)$$

Possible limits of changes in the concentration of minerals in the outlet stream, for this option, determined by the inequality:

$$C_1 < \frac{C_1 Q_{10} + C_2 Q_{20}}{Q_{10} + Q_{20}} \leq C_T \leq C_2 \quad (13)$$

The volume of the output stream will lie within:

$$Q_{20} \leq Q \leq Q_{10} + Q_{20}$$

In the case of using option (c) it becomes possible and necessary to control not only the concentration of minerals, but also the volume of the output flow Q_1 . Required concentration C_T can be specified within inequality (1). Let us find out the permissible range of setting the output volumetric flow Q_T . From relations (6) and (9) you can get:

$$\left. \begin{aligned} Q_1 &= \frac{C_2 - C_T}{C_2 - C_1} Q_T; \\ Q_2 &= \frac{C_T - C_1}{C_2 - C_1} Q_T; \end{aligned} \right\}$$

Where (13) equalizes:
$$\frac{Q_1}{Q_2} = \frac{C_2 - C_T}{C_2 - C_1} \quad (14)$$

Considering that the inequalities must be satisfied: $Q_1 \leq Q_{10}$, $Q_2 \leq Q_{20}$

$$\left. \begin{aligned} Q_T &\leq \frac{C_2 - C_1}{C_2 - C_T} Q_{10} \\ Q_T &\leq \frac{C_2 - C_1}{C_T - C_1} Q_{20} \end{aligned} \right\}$$

Whence we finally have

$$0 \leq Q_T \leq \min \left\{ \frac{C_2 - C_1}{C_2 - C_T} Q_{10} > \frac{C_2 - C_1}{C_T - C_1} Q_{20} \right\} \quad (15)$$

Thus, the possible volume of the output flow, in the case of accepting option (c) depends on the value of the required concentration.

Construction for a selective selection of purification or direct water supply to the mixing capsule implements the logic of operation based on equations (14) and (15).

The main principle of the proposed design is to create the required concentration of water with an acceptable salt content inside the tank and then transfer it for irrigation.

IV. CONCLUSION

This model can fully technical implement the above diffusion mixing scheme. The key factor is an indicator of the salinity levels of 1 and 2 streams based on the overall balance, a nominal salinity level is created, which was required at the beginning of the task of this study. The main indicator of operation regulation based on the concentration of the salt content level inside the mixer.

This model has following not researched parts and need making future analyze of system

1. Adequacy of this system must tested in technical prototype, however theoretical calculations shows that system is objective but aggressive habitat not yet researched.



ISSN: 2350-0328

International Journal of Advanced Research in Science, Engineering and Technology

Vol. 8, Issue 5 , May 2021

2. Operative reaction of system linked on sensors reaction speed and calculations must taking in account this factor.
3. System focus on close purification systems in addition for purification sets on base of mechanical cleaning like reverses osmosis and for open factories, this model could not be adequacy.

REFERENCES

- [1] Abdurakhmanov M.A., Rakhimov Y.T. The state of land resources in the Republic of Uzbekistan. The territory of science. 2017. No. 4, pp 37-40.
- [2] Rudakov V.K. Protection of territories during hydraulic engineering and land reclamation construction. - Kiev: Harvest, 1987 .104 p.
- [3] Problems of basin management in the context of climate change. Sat. scientific. Proceedings. Networks of water management organizations in Eastern Europe, Caucasus, and Central Asia. Issue 10. - Tashkent: // SIC ICWC, 2017.208 p.
- [4] Report FAO (food and agriculture organization) Resp. editors P.V. Krasilnikov, M.V. Konyushkova, R. Vargas Land resources and food security of Central Asia and the Caucasus, 2018.15-18 pp.
- [5] Hoffman G.J., Shalhevet J. Controlling Salinity. In Design and Operation of Farm Irrigation Systems, 2nd Edition (pp. 160-207). // American Society of Agricultural and Biological Engineers. 2007.
- [6] Gazieva R., Ozodov E. Automatic diffusion mixing system for watering in regions with high water sales. 1-3. 10.1109/ICISCT47635.2019.9011841.
- [7] Staroletov, Sergey. (2017). Design and Implementation a Software for Water Purification with Using Automata Approach and Specification Based Analysis. 10.31144/si.2307-6410.2017.n10.p33-44.
- [8] Dubey, Swati & Agarwal, Madhu & Gupta, Akhilendra & Dohare, Rajeev & Upadhyaya, Sushant. (2016). Automation and control of water treatment plant for defluoridation. International Journal of Advanced Technology and Engineering Exploration. 4. 6-11. 10.19101/IJATEE.2017.426002.
- [9] Gaziyeva R., Ozodov E. Design and development of arduino based automatic pH range monitoring system for optimum use of water in agricultural fields, Sustainable agriculture, 2