



ISSN: 2350-0328

**International Journal of Advanced Research in Science,
Engineering and Technology**

Vol. 5, Issue 2 , February 2018

Evaluation of the Different Methods of Spent Caustic Treatment

SeyedHadi Seyedin, Majid Hassanzadeganroudsari*

Department of Chemical Engineering, Science and Research Branch, Islamic Azad University, Tehran, Iran.
Collage of Health and Biomedicine, Victoria University, Melbourne, VIC and Department of Chemical Engineering, Science and Research Branch, Islamic Azad University, Tehran, Iran.

ABSTRACT: In recent years, refinery and petrochemical producer is forced by more stringent environmental regulations to better monitor and control their wastewater. One of the key contributors to relatively high chemical oxygen demand (COD) and biological oxygen demand (BOD) is from the acid gas (both CO₂ and H₂S) and mercaptan removal system(s) typically using dilute caustic soda (NaOH) as the active reagent. The resultant waste stream is otherwise known as spent caustic. It's difficult to clean up and dispose of due to its toxic properties. Today's various methods are used for treating spent caustic, such as wet air oxidation and direct acid neutralization. In this review, these methods were studied in detail and were compared together.

KEYWORDS: Treatment, Wastewater, Spent Caustic, Sodium Carbonate, Recovery.

I. INTRODUCTION

Sodium hydroxide (caustic) scrubbing solutions are commonly used in petrochemical and gas/petroleum refineries for the removal of acid components such as hydrogen sulfide, cresylic acids, mercaptan and naphthenic acids from the refined product streams [1]. Due to being hazardous, odorous, and/or corrosive components of spent caustic, handle and dispose of them, can be a challenge. Spent caustic streams may also have other characteristics that can create issues with conventional biological processes such as noxious odors, pH swings, foaming, or poor settling of biological solids [1]. Effluent requirements may be difficult to achieve because some spent caustic contaminants are not readily biodegradable. Typically, the material is disposed of by high dilution with bio treatment, acid neutralization, deep well injection, incineration, wet air/catalytic/Humid Peroxide Oxidation or other specialty processes [2]. The two basic methods for treating spent caustic solutions are wet air oxidation (WAO) and direct acid neutralization (DAN), respectively. In this paper, first spent caustics and then treatment methods were discussed in detail.

A) Spent Caustic

For ease of discussion, spent caustics will be classified into three general categories: Sulfidic, cresylic, and naphthenic: Sulfidic spent caustics produced from the caustic scrubbing of ethylene or LPG (light petroleum gas) products contain high concentrations of sulfides and mercaptans. Cresylic spent caustic, generated when scrubbing gasoline produced by fluidized bed catalytic cracking processes with caustic containing high concentrations of organic compounds including phenols and cresols. This type of spent caustic may also contain sulfides and mercaptans. Naphthenic spent caustic produced from the caustic scrubbing of kerosene and diesel products contain high concentrations of polycyclic aliphatic organic compounds such as naphthenic acids. Depending upon the types and quantity of products being produced, a refinery may have varying amounts of each of these categories of spent caustics that require treatment. In some instances, the spent caustics are combined to produce a mixture [2,3]. There are different problems with the treatment of spent caustic streams. Sulfides and mercaptans have very bad odors. The smell thresholds for these types of stuffs are generally in the order of values of parts per billion. Moreover, per OSHA, these matters are considered very toxic and can be potentially hazardous to plant staffs. This is particularly true in processes where the spent caustic is acid neutralized, which causes hydrogen sulfide and mercaptan gases to be escaped. High concentrations of phenols in the spent caustic effluent can lead to problems in biological treatment processes. Phenol in concentrations as low as 400 mg/L have been shown to prevent the elimination of COD, ammonia and phosphorous as



well as negatively affect the settling characteristics of the sludge.² It must be noted that in many refineries, the production of spent caustics including cresylic acids is performed as a batch process. This can lead to periodic disposal of phenols and cresols to the effluent treatment plant. It has been reported that sudden discharges of waste containing high concentration of phenols have caused perfect prevention of the biological clean up system. The spent caustic streams often include a variety of matters that are bio-refractory. Literature reviews show that naphthenic acids have been shown to have finite biodegradation in common biological treatment processes. Naphthenic acids have foaming specifications that can create problems when aerated or agitated during biological clean up. The untreated spent caustic streams are generally high in chemical oxygen demand (COD), in the range of 15 (g/L) to larger than 400 (g/L). Depending on the volume of spent caustic that is present; this can result in a huge COD load on downstream biological processes [1, 3].

B) Major Sources of Spent Caustic

1. Isomerization spent caustic.
2. Refinery spent caustic.

C) Isomerization spent caustic

It is used in ethylene cracker unit in order to caustic scrubbing of cracked gas. This solution is created by a caustic scrubbing column. Output ethylene product is contaminated with $H_2S(g)$ and $CO_2(g)$, and those contaminants are eliminated by absorption in the caustic scrubbing column to produce $NaHS(aq)$ and $Na_2CO_3(aq)$. The NaOH is used and the resulting effluent (spent caustic) is mixed with the sulfides and carbonates and a small component of organic compounds [8, 9].

D) Refinery spent caustic

It is created by various sources such as the Merox processing in some industrial plant like gasoline, kerosene, jet fuel; LPG, gas sweetening unit and the caustic scrubbing,. Sulfides and organic acids are eliminated from the product streams into the caustic phase. The NaOH is used and the resulting effluents (cresylic for gasoline; naphthenic for kerosene/jet fuel; sulfidic for LPG -spent caustics) are often mixed and called refinery spent caustic that is contaminated with sulfides, carbonates, and in some conditions a high fraction of heavy organic acids [8, 9].

II. COMPOSITION OF SPENT CAUSTIC

It is toxic and highly odorous. The list below shows typical analytical results:

1. Chemical Oxygen Demand (COD): 10,000 to 100,000 (mg/L).
2. Biochemical Oxygen Demand (BOD): 5,000 to 50,000 (mg/L).
3. Total Organic Carbon (TOC): 1,000 to 5,000 (mg/L).
4. Sulfides: 5,000 to 35,000 (mg/L).
5. High pH value.

Table 1. Permissible limit of Environmental Indicators.

Environmental Indicators	Permissible Limit (mg/L)
BOD	80-1600
COD	200-4000
TOC	80-260
Sulphide as H_2S	3

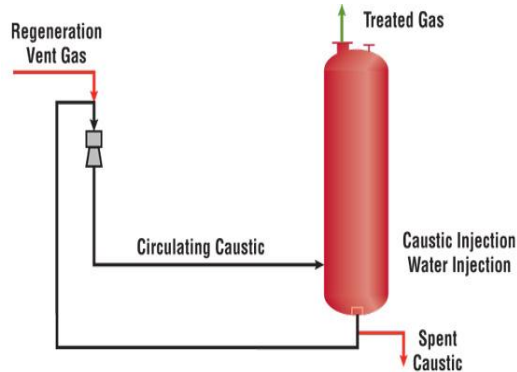

Fig 1.Schematic design of spent Caustic that is produced in various industries.

A) Common Treatment Processes

1. Chemical oxidation.
2. Neutralization.
3. Dilution Treatment.
4. Wet Air Oxidation (WAO).

B) Wet Air Oxidation Technology Process

The hydrothermal or WAO clean-up is a high temperature process for oxidation of matters which are solved or suspended in water with oxygen [4]. In the other words, WAO is the process of oxidizing organic stuffs in the presence of water. Theoretically, each substance that is able to burning can be wet oxidized in water. Spent caustic has high COD. This is not accepted in biological water purification plant. Wet air oxidation system oxidizes sulphides and mercaptans to reduce COD of spent caustic. After cleaning with WAO the wastewater has a lower COD and can then be treated in the biological refinement plant [5].

The oxidation reactions are performed at elevated temperatures requiring a pressurized system in order to control evaporation. The WAO technology when utilized for the treatment of spent caustic can be further divided into three categories based upon the temperature that is used to perform the oxidations [1,3].

- Low temperature WAO – typically performed at 110-120 °C and (25 to 100 psig).
- Mid Temperature WAO - typically performed at 200-220 °C and (300 to 600 psig).
- High Temperature WAO - typically performed at 240-260 °C and (700 to 1100 psig) Low temperature WAO has been historically utilized for the treatment of reactive sulfides in spent caustic, while mid and high temperature WAO has been utilized for the complete clean-up of sulfides and mercaptans also the treatment of organic components such as cresylic acids and naphthenic acids.

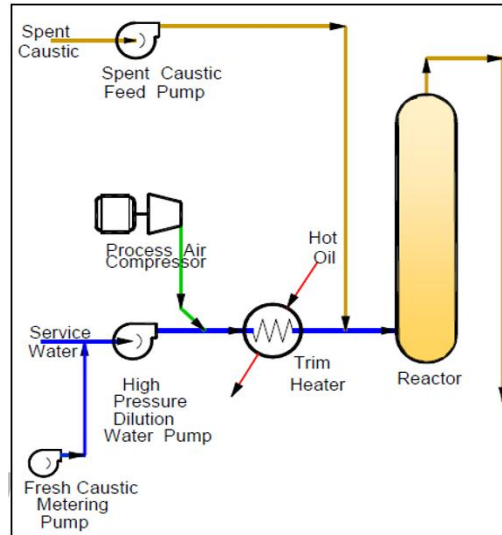

Fig 2.WAO Flow Diagram (Part A)[5]

In a conventional WAO system, the feed at a higher pressure is pumped to the system. The feed stream is pre-heated with outgoing wastewater from reactor in a heat exchanger and mixed with compressed air. The feed stream can also be heated before it enters the reactor. The hot fluid flow is then kept in a reactor for one-hour residence time at 200°C without any catalyst. The reactions occurred in liquid phase and the oxygen must be moved to the liquid phase from gas phase to do the reaction. Excess air is supplied to attain appropriate conversion. Sulphide compounds oxidize partially to form thiosulphate, moreover oxidation creates sodium sulphate. The organic materials present in the spent caustic are oxidized relatively. The total organic carbon is not affected much, but its nature is changed which results in lower COD and lower fouling rates.

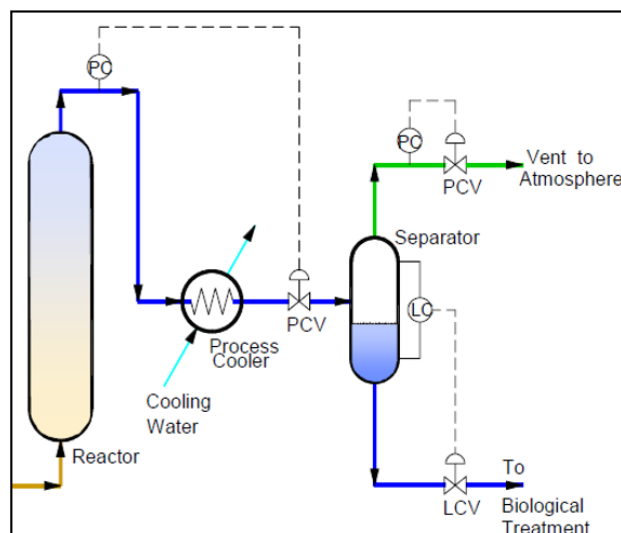
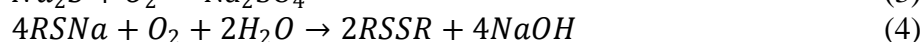
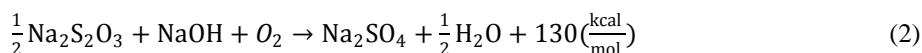
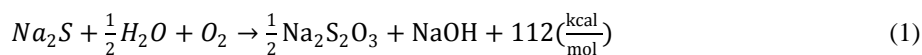

Fig 3.WAO Flow Diagram (Part B)[5]

The process also improves bio-treatability of the organic compounds. A simplified process flow diagram of the WAO was shown in figure 2. WAO is generally used as a waste treatment technology when the waste is non-conductive to incineration or biological treatment. It is an idealistic process for pretreatment of wastes that are problematic to

common biological equipment. The WAO process is uniquely adjusted to the oxidation of concentrated waste drinks, slurries, and sludge's where the oxygen requesting organic material is only a few percentages of the deliberately water flow.



C) Direct Acid Neutralization Method process

In the direct acid neutralization (DAN) treatment process, the spent caustic wastewater is acidified to release acidic components that were captured in the alkaline caustic solution. Sulphuric acid (98%) and hydrochloric acid are suitable. This results in sulfides and mercaptans being released as acid gases and naphthenic acids to be sprung as an oil layer or can be processed or incinerated in a sulfur improvement unit. One large differentiation between acid neutralization and WAO is that the acid components in the spent caustic are removed but not destroyed. In some cases, this results in additional treatment to be required. In others it allows for the capture and re-use of some of the components in the spent caustic. The neutralization reactions to reach pH of 7 or above are sum up as follows [1].

Caustic



Sodium sulphide

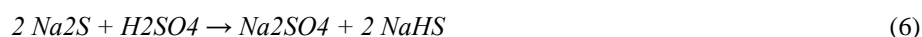

Sodium carbonate



Sodium mercaptide



Sodium phenolate



Each spent caustics including mercaptides or sulphides may be oxidized before neutralization to minimize COD of the final wastewater brine and sulfur amount of the neutralizer off gas. The control of pH in the neutralization stage is critical because the metallurgy is not designed for low pH operation (below 6). It is also important to minimize the production of gases such as H₂S from any remaining Na₂S and CO, from the sodium carbonate. Any mercaptans released in the neutralizer will also result in a highly odorous brine solution [3, 6].

III. RESULTS AND DISCUSSION**A) Results for Sulfiidic Spent Caustic (from LPG)**

Reduced Sulfur Concentrations: WAO at mid and high temperature destroyed the reduced sulfur components in the spent caustic to very low levels. Analysis of the effluent indicated that all sulfides and mercaptans were destroyed below detection limits. In comparison, the treated effluent from low temperature WAO conditions contained a substantial concentration of reduced sulfur compounds. Much of the reduced sulfur that was measured was caused by the partialoxidation of sulfides to thiosulfate. In mid and high temperature WAO conditions, nearly all of the sulfide was completely oxidized to sulfate. The low temperature WAO effluent also contained measurable concentrations of mercaptans where the mid and high temperature effluents did not. In acid neutralization processes, sulfides and mercaptans are stripped from the spent caustic and liberated into the gas phase. This process produces a wastewater that is low in reduced sulfur. However, the sulfide and mercaptans are not destroyed in the process and require further treatment, typically, either to an incinerator or a sulfur recovery plant [1]. Destruction of COD in Sulfidic Spent Caustic: The amount of COD destruction that was achieved during WAO increased with temperature. For example, a 65% COD reduction was achieved under low temperature WAO conditions while the destruction increased to 85% under mid temperature WAO conditions. Further increasing the temperature to high temperature WAO conditions did not significantly increase the amount of COD destruction. The majority of the COD in Sulfidic spent caustic is associated with decreased sulfur materials such as mercaptans and sulfides. It is, therefore, reasonable that the COD destruction data would be comparable to the reduced sulfur removal data. Similarly, acid neutralization would remove a significant portion of the COD in the wastewater by stripping sulfides and mercaptans into the gas phase. However, this COD is not destroyed and will need to be sent to either an incinerator or a sulfur unit [1,4].

B) Results for Naphthenic and Cresylic Spent Caustic Naphthenic Acid Destruction

In the WAO treatment process, as the temperature increases, the destruction of naphthenic acids increases. The concentration of naphthenic acids was also reduced when treated by the acid neutralization. Acid neutralization was able to remove over 75% of the naphthenic acids in the spent caustic. Also acid neutralization removes naphthenic acids as an insoluble oil layer. In this case the acid oil layer may be collected and recovered.

In this case the acid oil layer may be collected and recovered. In contrast, in wet air oxidation process, the naphthenic acids are not recovered but are destroyed and broken down into carbon dioxide and organic acids. Destruction of Phenols. Another factor that can influence treatment of spent caustic is the concentration of phenols. When the spent caustic was treated by WAO, the concentration of phenols decreased significantly.

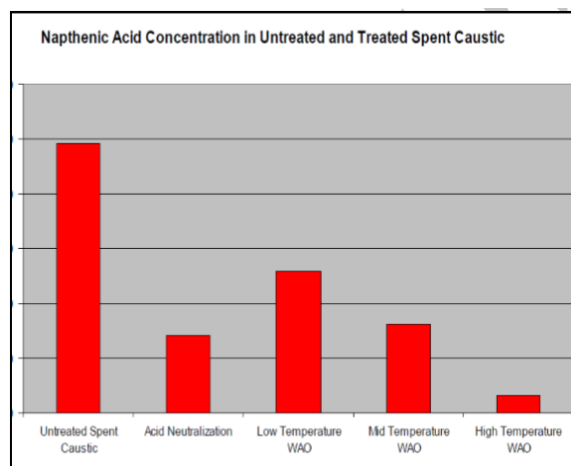

Fig 4. Expected Naphthenic Acid Results for Treated and Untreated Spent Caustic [1,4,7].

In low temperature WAO, the phenol concentration decreased in half. When the spent caustic was treated with mid and high temperature WAO, the concentration of phenols was decreased less than 1%. following acid neutralization treatment, the phenol concentration decreased slightly to 75%. This is most likely due to phenol being soluble in water and not easily removed by acidification.

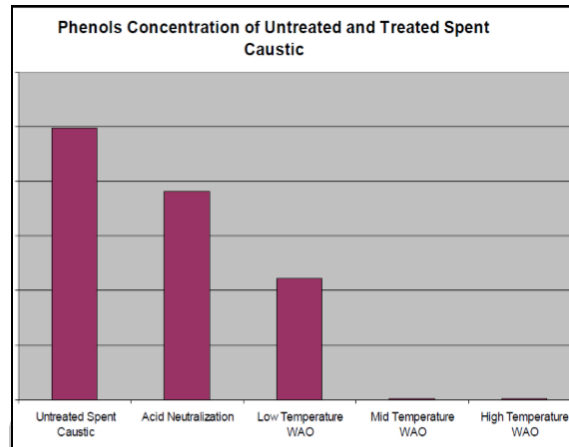

Fig 5. Expected Concentration of Phenol in Untreated and Treated Spent Caustic (mg/L) [1, 7].

Foaming Characteristics: Foaming is another key factor in the treatment of spent caustics. Naphthenic acids have a tendency to generate foam when agitated or aerated, which can cause issues in an aerated biological system. The calculated foaming index gives an indication of the relative foaming tendencies when comparing samples.

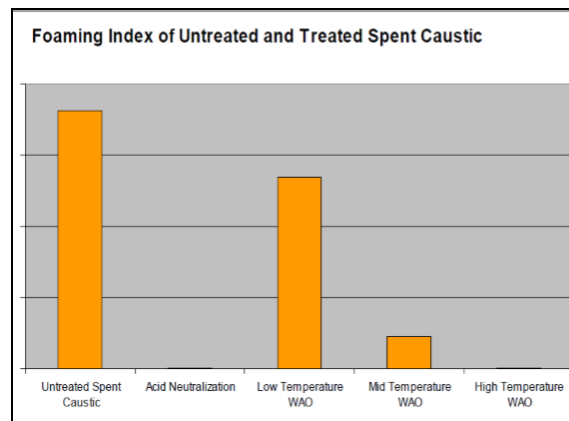

Fig 6. Foaming Index of Untreated and Treated Spent Caustic (mL) [1, 7].

The untreated spent caustic had a high foaming index. The spent caustic treated by acid neutralization and high temperature WAO had negligible foaming indexes. Treatment at low temperature WAO conditions, the foaming index was high and at medium temperature WAO conditions, the foaming index had decreased but was still high.

C) Destruction of COD in Naphthenic and Cresylic Spent Caustic

Since the majority of the COD in the untreated spent caustic was due to the naphthenic acids and phenols, the general COD reduction followed the same trends as the destruction of the specific compounds. Low temperature WAO had significantly less COD reduction than the high temperature conditions, with low temperature oxidation at 20%

destruction and high temperature at 70% destruction. Acid neutralization produces a similar COD reduction as the high temperature WAO; however, the COD was removed in the form of a separate liquid product instead of being destroyed. This separate liquid product stream has little value and will require either internal recycling in the refinery or off-site disposal [1,4,7].

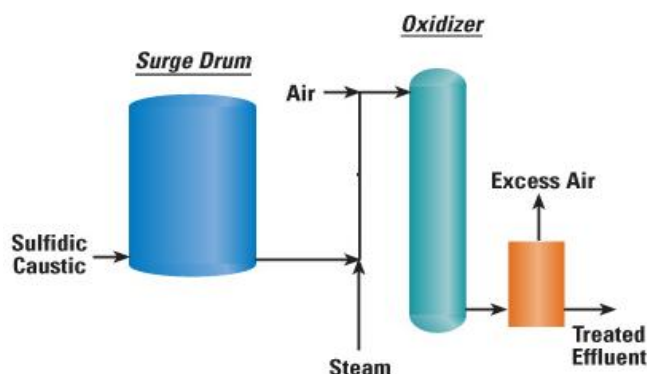

Fig 7. Schematic image of improved WAO process.

D) Consideration of Various Treatment Methods

1. Acid neutralization will reduce the COD bulk and foaming trend by eliminating the naphthenic acids but will not remove phenols or produce a biodegradable wastewater. In addition, any sulfides and mercaptans in the spent caustic will be released from the spent caustic into the gas phase and will further treatment in a separate unit operation. Acid neutralization does not destroy the COD but instead removes / separates it and *produces a separate product* requiring either further treatment of off-site disposal.

2. Low temperature WAO (110-120 °C) can oxidize a high percentage of sulfides and mercaptans but not to levels below the detection level and a significant amount of reduced sulfur will remain in the effluent in the form of thiosulfate. Mercaptans will not be oxidized below detection limits. Insufficient treatment of reduced sulfur compounds, phenols, and naphthenic acids will not produce a biodegradable wastewater. Low temperature WAO will not remove the foaming trend of the spent caustic if naphthenic acids are present in the spent caustic. Low temperature WAO is best applied to low strength Sulfidic spent caustic that does not contain any mercaptans or other acid oils. Special attention should also be given to the downstream biological treatment systems' ability to handle the reduced sulfur load from the thiosulfate.

3. Mid temperature WAO (200-220 °C) will oxidize sulfides, and mercaptans. Sulfides and mercaptans will be oxidized to non-detectable levels. A majority of the phenols and COD will be oxidized producing a biodegradable wastewater. Like low temperature WAO, mid temperature WAO will not remove the foaming trend of the spent caustic if naphthenic acids are present. Mid temperature WAO is best applied to Sulfidic caustics from LPG or ethylene scrubbing. Spent caustics containing cresylic compounds can also be successfully treated using the mid temperature WAO.

4. High temperature WAO (240-260 °C) will oxidize all reduced sulfur materials and phenols, remove the foaming trend of the spent caustic, and decrease a majority of the COD producing a biodegradable wastewater. High temperature WAO is best applied to refinery spent caustics used for treating heavy products and containing naphthenic constituents. High temperature WAO can also be used to treat mixed spent caustics that may contain naphthenic as well as cresylic and Sulfidic constituents.

IV. DESCRIPTION of NEW METHOD

In this project because of essential need of the industrial units to restore spent caustic following benefits are:



ISSN: 2350-0328

International Journal of Advanced Research in Science, Engineering and Technology

Vol. 5, Issue 2 , February 2018

1. The ability to remove hazardous compounds from wastewater without producing hazardous wastewater and without any environmental risk.
2. hazardous sodium sulfide (Na_2S) removal in wastewater.
3. The production of a valuable substance such as NaOH and sodium carbonate rather than neutralizing it by acid or drop it in water due to high pH that is very harmful for environment.

The use of a new and modern technology compared to other technologies with more advantages.

1. Storage of wastewater in reservoirs and separation of fats or oils.
2. Advanced oxidation (AO) of wastewater.
3. Separating of disulfide oil compounds.
4. Filtration process.
5. Concentration stage.

Advanced oxidation (AO) of wastewater, is performed by wet air, ozone molecule, UV ray and Appropriate catalyst.

A) Advantages of New Method

1. Existence of dangerous sulphurous compounds in wastewater of olefin unit and gas sweetening plant.
2. H_2S and CO_2 are included almost 10% off gases.
3. Large amount of caustic soda is used for neutralize of sulphurous compounds and is washed by water.
4. High concentration of pH output wastewater.
5. High COD levels decrease the amount of dissolved oxygen available for aquatic organisms.
6. Production of new product by means of cheap materials.
7. High interest of plan economically.

V. CONCLUSION

Advanced oxidation will oxidize all decreased sulfur materials and phenols, remove the foaming tendency of the spent caustic, and decrease a majority of the COD producing a biodegradable wastewater. AO is the best applied to refinery spent caustics used for treating heavy products and containing naphthenic constituents. AO can also be used to treat mixed spent caustics that may contain naphthenic as well as cresylic and sulfidic constituents. Type of spent caustic can determine the best treatment technique. AO found to be the most common treatment method to treat all type of spent caustics. Safety factor plays a major role in spent caustic treatment. Also after AO by means of useful process, the NaOH and Na_2CO_3 are produced.

REFERENCES

- [1] B. Kumfer, C. Felch and C. Maugans, "Wet Air Oxidation Treatment of Spent Caustic in Petroleum Refineries", the National Petroleum Refiners Association Conference Phoenix, AZ; March 21-23, 2010.
- [2] http://en.wikipedia.org/wiki/Spent_caustic
- [3] <http://www.spentcaustic.com/whataresp.html>
- [4] A. Waqar, "Neutralization of Spent Caustic from LPG Plant at Preem AB Göteborg", Ms.c Thesis in Chemical and Biological Engineering, Göteborg, Sweden, 2010.
- [5] T.M.S. Carlos, "Wet Air Oxidation of Refinery Spent Caustic: A Refinery Case Study", NPRA Conference, San Antonio, Texas September 12, 2000.
- [6] www.merichem.com/resourse/technical_paper/sa_fe_waste
- [7] M.V. Reboucas, "Analysis of Effluent from caustic Treatment Plants", Institute Colombiano del Petroleo, Colombia, pp. 163-170, 2006.
- [8] Claude E. Ellis, Robert J. Lawson, Bruce L. Brandenburg, WET AIR OXIDATION OF ETHYLENE PLANT SPENT CAUSTIC, Prepared for presentation at American Institute of Chemical Engineers Sixth Annual Ethylene Producers Conference, Annual Meeting Atlanta, Georgia USA, 17 April 1994 to 21 April 1994.
- [9] William L. Bider, Robert G. Hunt, INDUSTRIAL RESOURCE RECOVERY PRACTICES: PETROLEUM REFINERIES AND RELEATED INDUSTRIES, U.S. Enviromental Protection Agency, Office of solid waste, 1982.